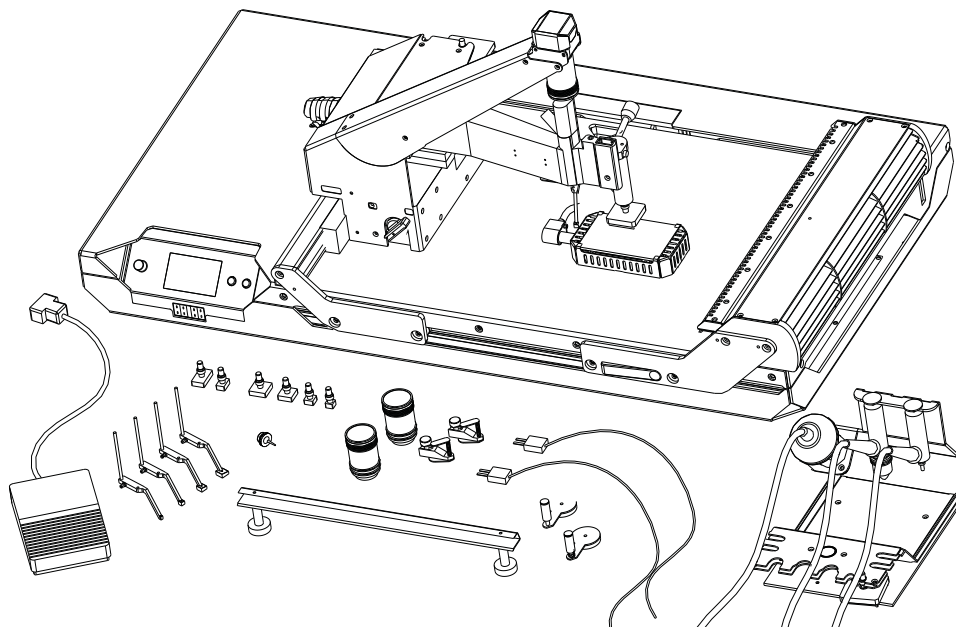

Rework Technic – EXPERT 10.6-IV

Rework Station with IR-Underheater 110W (60x80mm²) and automated SMD placement process by Auto Vision Placer (AVP), incl. Easy Solder software package and DBL 06 control unit with six high resolution sensor inputs for thermocouples (Type K).

This system is particularly suitable for small PCBs which you can find in Smartphones and PDAs with Fin Pitch components in varying package dimensions.

Standard Equipment (Art.No. DB00.1068)

- Tool set for dispensing, placing, residual solder removal and soldering with magazine.
- Set of placement nozzles (BGA/CSP) 3mm, 5mm, 8mm, 10mm
- Set of soldering nozzles (CSP/QFN), 9mm, 11mm 13mm, 16mm
- Set of soldering nozzles (SO) 10x15mm², 15x25mm²
- Placement nozzle for manual placement of small components (0,5mm)
- Two camera lenses (BGA und CSP)
- Two thermo couple sensors (Type K)
- Two PCB magnet holder 40,5mm (standard)
- PCB magnet holder rail 40,5mm
- Two PCB clips to install at hand rest
- Foot switch
- Rework ABC and manual







Technical Data

System power consumption:	1000 VA	
Power solder pen:	300 W, 35 l/min	
Power underheater:	110 W, 2 x IR lamps	
Effective heating area:	60 x 80 mm ²	
Recommended PCB size max:	80 x 100 mm ²	
Resolution motion system:	0,001 mm	
Placement accuracy :	± 0,015 mm	(Flip Chip)*
	± 0,030 mm	(CSP)
	± 0,040 mm	(BGA)
High resolution CMOS-camera:	5 Mio. Pixel, USB2	
	14 x 18 mm ²	(Flip Chip)*
	28 x 37 mm ²	(CSP)
	37 x 50 mm ²	(BGA)
Mains:	1 Phase, 230VAC, Fuse 16A	
Pressurized air:	5 - 8 bar, 100l/min clean dry air	
Foot print:	460 x 865 mm ²	

*Optional Extras

Rework Technic – EXPERT 10.6-IV

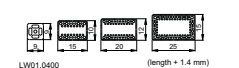
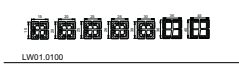
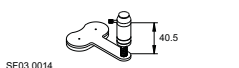
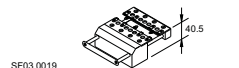
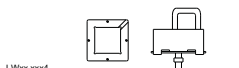
Optional extras

SF66.0004	Micro SMD nozzles and lens for AVP 4 licence MS, 3 n, 3 solder n, lens FC		1 piece
DVSX.0007	Report with pcb identification for ES 05, licence RP		1 piece
SF66.0110	Lens Maxi BGA for AVP4/4XL, f=16mm, 65*85mm		1 piece
LW40.1099	Solder nozzle set BGA 7 for all (98%) types of BGA, 7 pieces		1 piece
LW01.0400	Soldering tool set SO (lead free)* for all SO...SOL...TSOP, 4 pieces		1 piece
LW01.0100	Soldering tool set QFP for all PLCC ...QFP, 7 pieces		1 piece
SF03.0014	PCB magnet holder Easy Lock 40.5 (snap) for IR/IRD/IRH/IRF radiation element		1 piece
SF03.0019	PCB clamping holder 40.5 with 3 fingers for mobil phone pcs on HB05/IR/IRD/IRH/IRF		1 piece
LWxx.xxx4	Reballing oven and masks for all types of BGA/CSP, your choice		1 piece
SF71.0001	Side Camera for ES 05, camera, stand, cable, DVD		1 piece
DB00.0025	Nitrogen input for DBL 04/05/06 (2.p.r) reduces consumption of N2 for vacuum		1 piece